

- 短型，高速，輕量型回轉油壓缸。
- 內建逆止閥自鎖機構及壓力洩壓閥。
- 安裝時可由後端鎖固之。
- 洩油孔配管務必單獨接回油壓槽，以避免發生背壓。
- For short form, light weight and high speed rotary cylinder.
- Built-in safety check valves and pressure relief valves.
- Can screw it from the rear end of the cylinder when mounting.
- The drain port should be independently connected to oil tank to avoid back pressure.

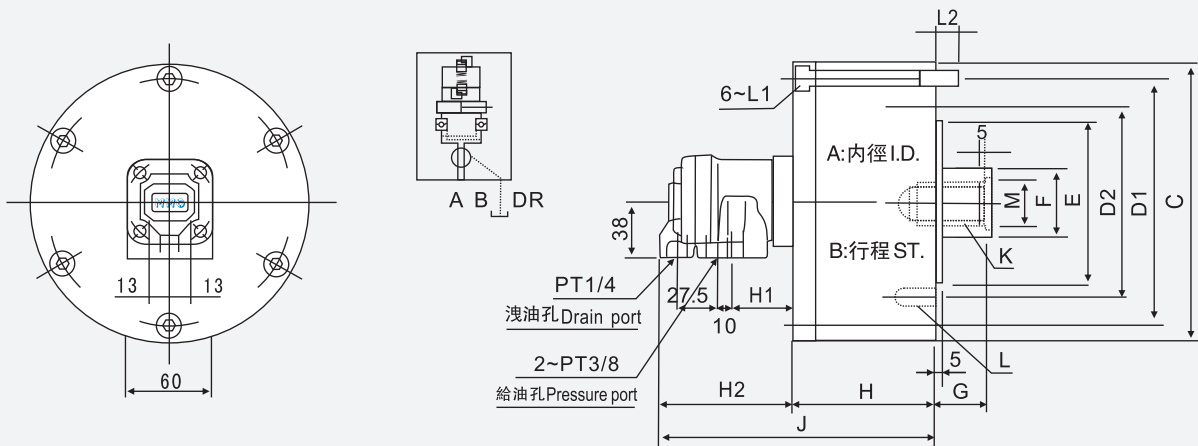

規格 Spec 型號 Model	活塞面積 Eff. piston area cm ²		行程 mm Piston stroke	最高使用回轉數 r.p.m Max. speed	最高使用壓力 MPa Max. pressure (kgf/cm ²)	GD ² kg.m ² Moment or inertia	重量 kg Weight
	押側 Extend	拉側 Retract					
RK-75N	44.2	37.1	15	6000	4.0(40)	0.01	2.9
RK-100N	78.5	71.5	20	6000	4.0(40)	0.03	4.3
RK-125N	122.7	113.1	25	6000	4.0(40)	0.05	6.9
RK-150N	176.7	160.8	30	5500	4.0(40)	0.09	9.4
RK-200N	314.1	290.4	35	5500	4.0(40)	0.28	15.3

寸法 Size 型號 Model	A	B	C	D1	D2	E h7	F	G		H	H1	H2	J	K	L	L1	L2	M h8
								max.	min.									
RK-75N	75	15	107	90	90	65	30	45	30	57	42	91	134	M20×35	6-M8×16	M8×60	12	21
RK-100N	100	20	132	115	100	80	30	45	25	72	42	91	149	M20×35	6-M10×20	M8×75	12	21
RK-125N	125	25	160	140	130	110	35	50	25	82	41	90	159	M24×45	6-M12×20	M8×85	12	25
RK-150N	150	30	190	170	130	110	45	55	25	95	39	89	172	M30×45	12-M12X24	M10×100	16	31
RK-200N	200	35	245	220	145	120	55	70	35	115	36	86	192	M35×60	12-M16X30	M10×125	16	37